

**Description**

Standard Duty Hand Riveting Tool

This tool installs 3.0 – 5.0mm rivets in all materials.  
Nose tips are quick and easy to change, and are conveniently located on the tool handle.

**\*\* Tool is also available as a kit, pictured below (ExtraK39)**

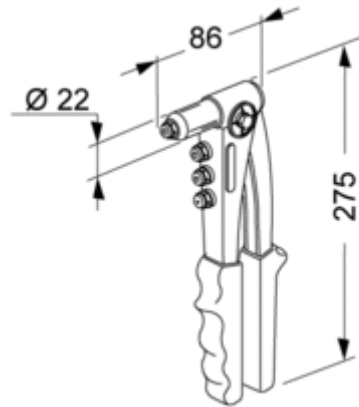

**Specifications**

<b>Model</b>	TA-K39
<b>Type</b>	Plier Type
<b>Construction</b>	Pressed Metal Frame
<b>Capacity</b>	3.0 – 5.0mm all materials
<b>Weight</b>	0.55kg

Dimensions and specifications are subject to change without notice.  
Check you distributor for the latest data sheet

As this data is based on multiple tests in various thicknesses we recommend testing the fastener in your application when an exact strength figure is required, or the load to be applied comes close to the published data