

**Description** Hydro-pneumatic Structural Riveting Tool with vacuum mandrel extraction

This solid reliable tool features a double acting hydro-pneumatic actuation resulting in a quick cycle time while maintaining a high traction force. Capacity is up to 1/4" (6.4mm) structural rivets in all materials. The RAC171 model also features vacuum mandrel extraction as well as a mandrel container at the rear for spent mandrels. The RAC171 is the tool of choice for installers of structural rivets in any material.

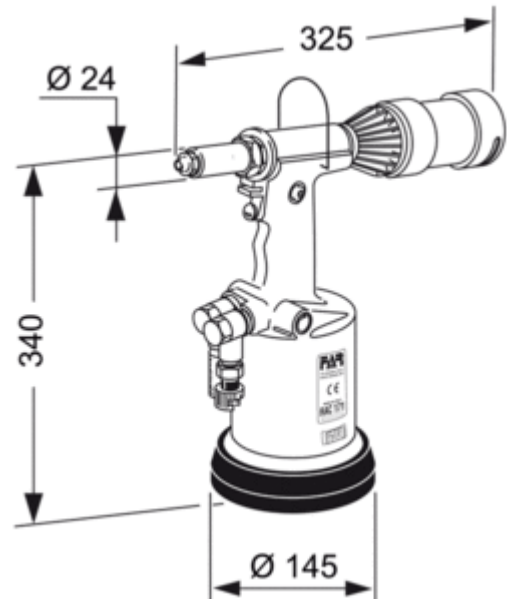

Switchable Vacuum



**Specifications**

<b>Model</b>	RAC171
<b>Type</b>	Hydro-Pneumatic
<b>Construction</b>	ABS Plastic & Steel
<b>Capacity</b>	1/4" Structural or smooth stem rivets in all materials
<b>Weight</b>	2.90kg
<b>Traction Force</b>	6 bar – 1750 kg

Dimensions and specifications are subject to change without notice. Check your distributor for the latest data sheet

As this data is based on multiple tests in various thicknesses we recommend testing the fastener in your application when an exact strength figure is required, or the load to be applied comes close to the published data

Profast Pty Ltd QLD

P: +61 7 3265 2267

F: +61 7 3265 2257

E: salesQLD@profast.com.au

W: www.profast.com.au

Profast WA Pty Ltd

P: +61 8 9456 5537

F: +61 8 9455 2659

E: salesWA@profast.com.au

W: www.profast.com.au