

Description

Large flange Euro – Stainless Steel

Optimal for high push-out applications that require a stainless-steel fastener. Uses hard metric holes. Tapered entry. Torque to turn resistance of plus 50% on smooth, round bodied inserts.



Material Stainless Steel A2
Finish Natural

Specifications

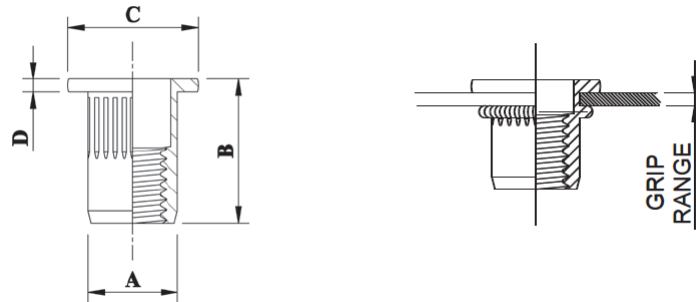

Dimensions

Part Code	Thread Size	Grip Range	Hole Size +0.1	A Max	B ±0.3	C ±0.3	D +0.2
IN18-23020	M3 x 0.5	0.5 – 2.0	5.00	5.00	9.00	8.00	0.80
IN18-24025	M4 x 0.7	0.5 – 2.5	6.00	6.00	11.00	9.00	1.00
IN18-24040	M4 x 0.7	2.5 – 4.0	6.00	6.00	12.50	9.00	1.00
IN18-25030	M5 x 0.8	0.5 – 3.0	7.00	7.00	12.00	10.00	1.00
IN18-25045	M5 x 0.8	3.0 – 4.5	7.00	7.00	13.50	10.00	1.00
IN18-26030	M6 x 1.0	0.5 – 3.0	9.00	9.00	14.00	12.00	1.50
IN18-26050	M6 x 1.0	3.0 – 5.0	9.00	9.00	16.00	12.00	1.50
IN18-28030	M8 x 1.25	0.5 – 3.0	11.00	11.00	16.00	15.00	1.50
IN18-28055	M8 x 1.25	3.0 – 5.5	11.00	11.00	18.50	15.00	1.50
IN18-20035	M10 x 1.50	1.0 – 3.5	13.00	13.00	19.00	17.00	2.00
IN18-20060	M10 x 1.50	3.5 – 6.0	13.00	13.00	21.50	17.00	2.00

Thread Size	Pull-Out KN	Push-Out KN	Ultimate Torque Nm
M3 x 0.5	4.903	2.94	2.94*
M4 x 0.7	7.84/8.33	3.92	6.86*
M5 x 0.8	14.70/15.69	4.90	9.80*
M6 x 1.0	20.59/22.55	8.35	14.71/19.61*
M8 x 1.25	34.32/40.20	9.80	49.03*
M10 x 1.50	50.99/49.03	12.74	**
M12 x 1.75	60.80	19.61	**

indicative strength figures only. Figures showing two values represent 1st grip/2nd grip values

* Test using 12.9 high strength allow screw to test. Screw broke at neck but inner thread was undamaged

**Beyond testing equipment's capacity of 98.06Nm

Dimensions and specifications are subject to change without notice.

Check your distributor for the latest data sheet

As this data is based on multiple tests in various thicknesses we recommend testing the fastener in your application when an exact strength figure is required, or the load to be applied comes close to the published data

Profast Pty Ltd QLD

P: +61 7 3265 2267

F: +61 7 3265 2257

E: salesQLD@profast.com.au

W: www.profast.com.au

Profast WA Pty Ltd

P: +61 8 9456 5537

F: +61 8 9455 2659

E: salesWA@profast.com.au

W: www.profast.com.au