

Description

Standard Duty Hand Riveting Tool and rivet kit

This tool installs 3.0 – 5.0mm rivets in all materials. Nose tips are quick and easy to change, and are conveniently stored in the case provided. This tool is supplied in kit form including storage case. This kit also includes a range of 3.2, 4.0 and 4.8mm rivets as part of the package, making it ideal for the home user or jobbing shop.

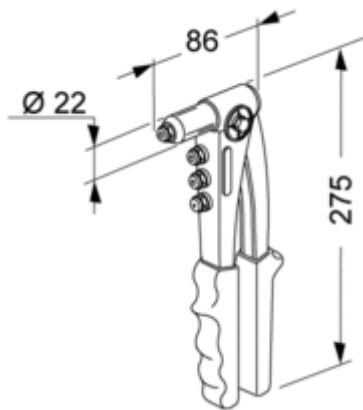

Specifications

Model	K39
Type	Plier Type
Construction	Pressed Metal Frame
Capacity	3.0 – 5.0mm all materials
Weight	0.55kg

Dimensions and specifications are subject to change without notice. Check you distributor for the latest data sheet

As this data is based on multiple tests in various thicknesses we recommend testing the fastener in your application when an exact strength figure is required, or the load to be applied comes close to the published data

Profast Pty Ltd QLD
Profast Pty Ltd NSW
Profast WA Pty Ltd

P: +61 7 3265 2267
P: 0408 153 589
P: +61 8 9456 5537

F: +61 7 3265 2257
F: +61 7 3265 2257
F: +61 8 9455 2659

E: salesQLD@profast.com.au
E: salesNSW@profast.com.au
E: salesWA@profast.com.au

W: www.profast.com.au
W: www.profast.com.au
W: www.profast.com.au