

**Description**

Heavy Duty Structural Rivet Hand Tool 3/16" & 1/4"

This tool installs 3/16" & 1/4" Structural Rivets the extendable long arms provide the leverage required to set structural rivets quickly and easily.



\*\*K35F pictured above, K33F similar

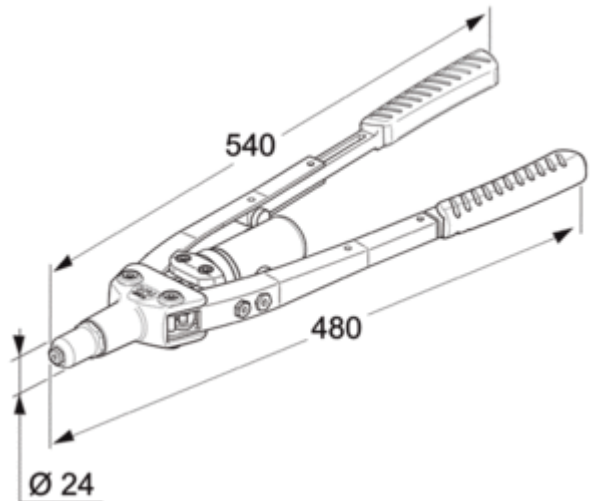

<b>Model</b>	TA-K33F
<b>Type</b>	Extending Long Arm
<b>Construction</b>	Pressed Metal Frame
<b>Capacity</b>	3/16" & 1/4" Structural Rivets
<b>Weight</b>	1.7kg

Dimensions and specifications are subject to change without notice. Check your distributor for the latest data sheet

As this data is based on multiple tests in various thicknesses we recommend testing the fastener in your application when an exact strength figure is required, or the load to be applied comes close to the published data

Profast Pty Ltd QLD

P: +61 7 3265 2267

F: +61 7 3265 2257

E: salesQLD@profast.com.au

W: www.profast.com.au

Profast WA Pty Ltd

P: +61 8 9456 5537

F: +61 8 9455 2659

E: salesWA@profast.com.au

W: www.profast.com.au