

## Description

Heavy Duty Multi-purpose Tool - Interchangeable nose

This heavy duty production tool is specifically designed for the efficient installation of a wide range of structural blind rivets, lockbolts and Max grip fasteners up to and including 3/8" diameter. Weighing 5kg it can be operated in any position with one hand. With a long 24.4mm stroke it's capable of setting most fasteners in one pull.

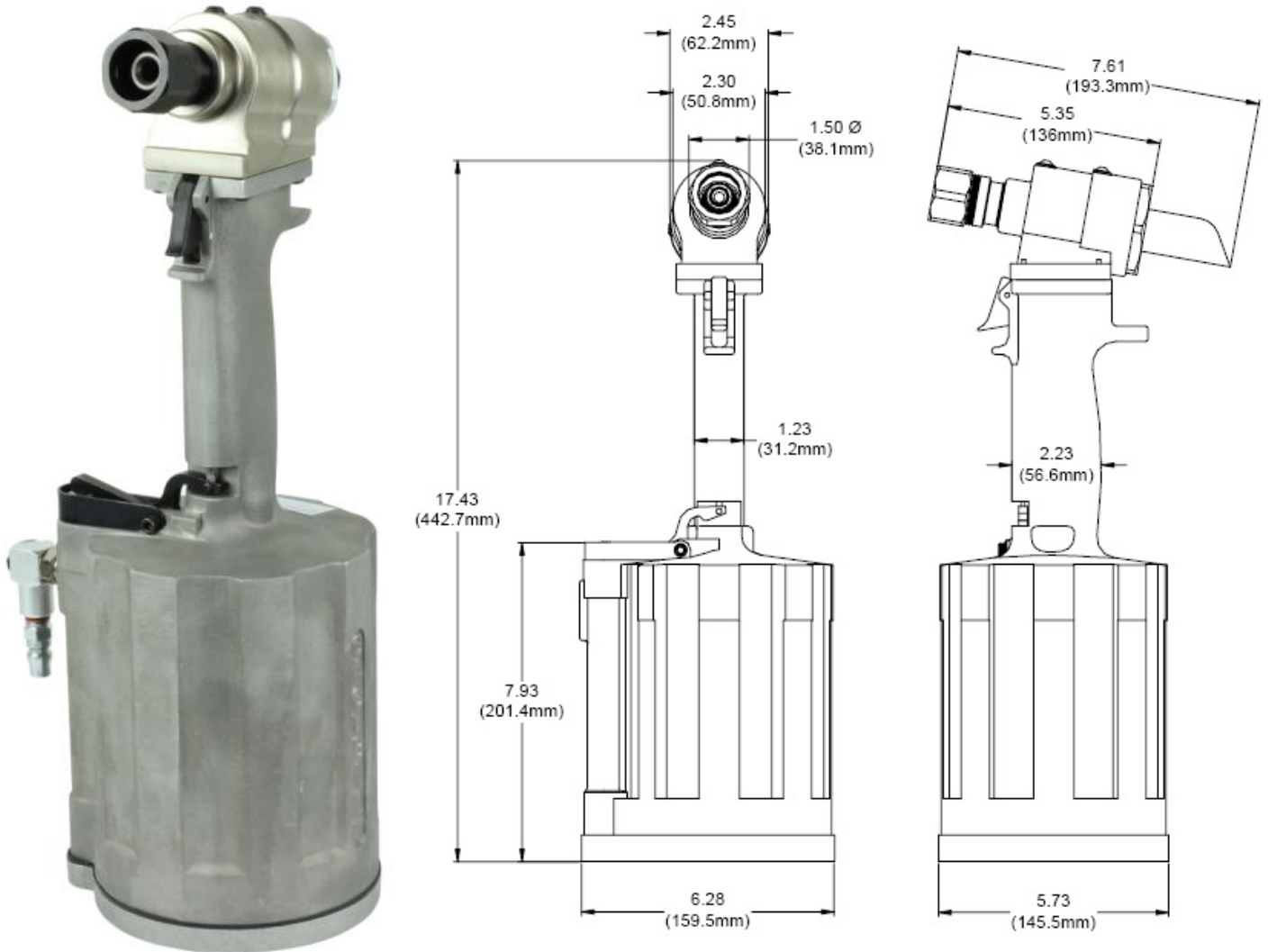

\*\* Noses sold separately

## Specifications

<b>Tool Model</b>	TA-756
<b>Type</b>	Heavy duty multi-purpose
<b>Capacity</b>	1/4" – 3/8" Structural Rivets & two-piece fasteners
<b>Weight</b>	5.04kg

Dimensions and specifications are subject to change without notice.  
Check your distributor for the latest data sheet

As this data is based on multiple tests in various thicknesses we recommend testing the fastener in your application when an exact strength figure is required, or the load to be applied comes close to the published data

Profast Pty Ltd QLD  
Profast Pty Ltd NSW  
Profast WA Pty Ltd

P: +61 7 3265 2267  
P: 0408 153 589  
P: +61 8 9456 5537

F: +61 7 3265 2257  
F: +61 7 3265 2257  
F: +61 8 9455 2659

E: salesQLD@profast.com.au  
E: salesNSW@profast.com.au  
E: salesWA@profast.com.au

W: www.profast.com.au  
W: www.profast.com.au  
W: www.profast.com.au